



# INSTALLATION INSTRUCTIONS FOR CENTRAX® CENTRIFUGAL FAN

## READ AND SAVE THESE INSTRUCTIONS IMPORTANT SAFETY INSTRUCTIONS

With the use of any electrical appliance, it is important to observe all basic precautions to minimize the risk associated with use, such as electrical shock, fire, or injury to persons. If this unit is installed in a bathroom or kitchen, power must be supplied from a ground fault circuit interruptor (GFCI). Read these instructions before using your Centrax® fan.

**NEVER EXPOSE YOUR CENTRAX® FAN TO TEMPERATURES OVER 140°F (60°C)**

### INSTALLATION

1. Install mounting brackets to fan. (Refer to Figure 1)
2. Secure mounting brackets to a fixed structure. (Refer to Figure 2)
3. Connect the Centrax® to ventilation system using 6 #6 screws (supplied) when connecting to rigid duct or 2 cable ties (supplied) when connecting to flex duct.
4. Connect to power source. (Refer to Figure 3)

**CAUTION:** Before carrying out any maintenance or servicing, ensure the unit is disconnected from the main supply.  
**FOR GENERAL VENTILATION USE ONLY. DO NOT USE TO EXHAUST HAZARDOUS OR EXPLOSIVE MATERIALS AND VAPORS OR DUST.**  
 Use supply wires suitable for 105°C.

### WARNING - TO REDUCE THE RISK OF FIRE, ELECTRIC SHOCK, OR INJURY TO PERSONS, OBSERVE THE FOLLOWING:



- a) Use this unit only in the manner intended by the manufacturer. If you have questions, contact the manufacturer.
- b) Before servicing or cleaning unit, switch power off at service panel and lock the service disconnecting means to prevent power from being switched on accidentally. When the service disconnecting means cannot be locked, securely fasten a prominent warning device such as a tag to the service panel.
- c) Installation work and electrical wiring must be done by a qualified person(s) in accordance with all applicable codes and standards, including fire-rated construction.
- d) When cutting or drilling into walls or ceilings, avoid damaging electrical wiring and other hidden utilities.
- e) Ducted fans must always be vented to the outdoors.
- f) If this unit is to be installed over a tub or shower, it must be marked appropriately for the application and be connected to a GFCI (Ground Fault Circuit Interrupter) protected branch circuit.
- g) NEVER place a switch where it can be reached from a tub or shower.
- h) When used in an attic, install exhaust side of the fan facing an unoccupied space.
- i) This unit has an unguarded impeller. Do not use in locations readily accessible to people or animals.
- j) Sufficient air is needed for proper combustion and exhausting of gases through the flue (chimney) of fuel burning equipment to prevent back drafting. Follow the heating equipment manufacturer's guideline and safety standards such as those published by the National Fire Protection Association (NFPA), and the American Society for Heating, Refrigeration and Air Conditioning Engineers (ASHRAE), and the local code authorities.

### MOUNTING HARDWARE INCLUDED

Model	#8 x 1" Self Tapping Screw	#8 x 5/8" Machine Screw	Hex Nut	#6 Lock Washer	Rubber Washer	Flat Washer	Mounting Bracket
TF104(-W)	Qty. 4	Qty. 4	Qty. 4	Qty. 4	Qty. 4	Qty. 4	Qty. 2
TF106 & TF108	Qty. 8	Qty. 8	Qty. 8	Qty. 8	Qty. 8	Qty. 8	Qty. 4

  

Model	#10 x 1" Self Tapping Screw	#10 x 5/8" Machine Screw	Hex Nut	#10 Lock Washer	Rubber Washer	Flat Washer	Mounting Bracket
TF110 & TF112	Qty. 8	Qty. 8	Qty. 8	Qty. 8	Qty. 8	Qty. 8	Qty. 4

	Qty. 6	#6 Screws For Securing Rigid Duct Connection (Included in all units)
	Qty. 2	Cable Ties For Securing Flex Duct Connection (Included in all units)

## FIGURE 1: MOUNTING BRACKETS

**NOTE:** Rubber washer must be placed between bracket and housing.

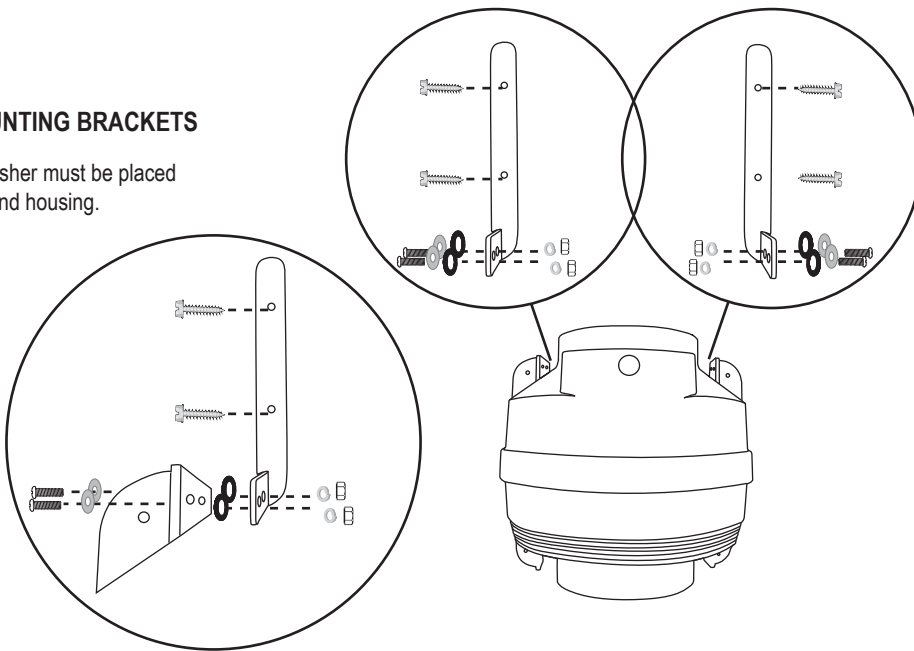

## FIGURE 2: MOUNTING

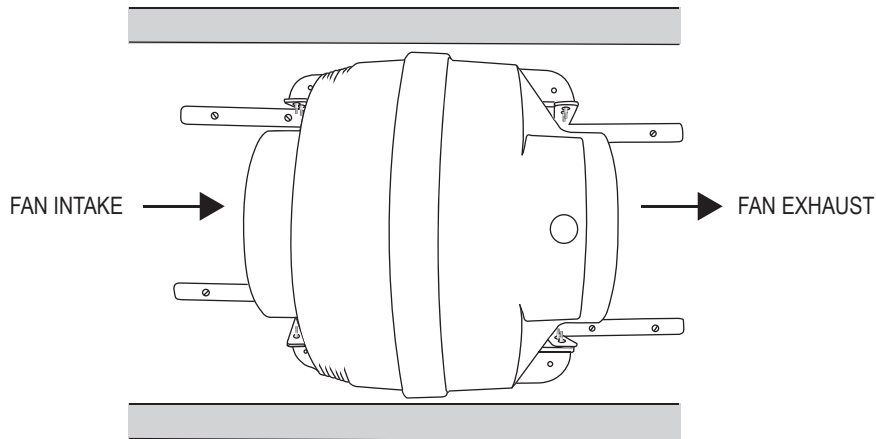

## MAINTENANCE

Inspect the product at least once every 12 months for excessive dust and dirt build-up on the impeller (more frequently in dusty environments). Clean as necessary. The unit must be disconnected from power during inspection and/or cleaning.

## FIVE YEAR LIMITED WARRANTY

Subject to the following limitations, Suncourt Inc. (manufacturer) warrants that the Centrax® centrifugal fan will, for 5 (five) years from date of original purchase, remain free from appearance of defects in workmanship or materials. This warranty is subject to the following limitations: (a) manufacturer's liability is limited to the replacement or repair of the unit, as decided by the manufacturer; (b) a defective unit must be returned, prepaid, with proof of purchase, to Suncourt; and (c) this warranty does not apply to defects resulting from the alteration, abuse, accidental damage, unauthorized repair, or misuse of the unit. This warranty is given in lieu of all other warranties, guarantees, and conditions on manufacturer's part, and the manufacturer shall have no tortious or other liability in respect to this Centrax® centrifugal fan.

Actual product appearance may differ from illustrations.

Suncourt reserves the right to modify any or all of its products' features, designs, components and specifications without notice.

### TOOLS NEEDED:

